

POWERWALL

Tesla Powerwall is a fully-integrated AC battery system for residential or light commercial use. Its rechargeable lithium-ion battery pack provides energy storage for solar self-consumption and time-based control.

Powerwall's electrical interface provides a simple connection to any home or building. Its revolutionary compact design achieves market-leading energy density and is easy to install, enabling owners to quickly realise the benefits of reliable, clean power.



PERFORMANCE SPECIFICATIONS

AC Voltage (Nominal)	230 V
Feed-In Type	Single Phase
Grid Frequency	50 Hz
Total Energy ¹	14 kWh
Usable Energy ¹	13.5 kWh
Grid Standards (UK)	G83 / G59
Real Power, max continuous	3.68 kW / 5 kW (charge and discharge)
Apparent Power, max continuous	3.68 kVA / 5 kW (charge and discharge)
Power Factor Output Range	+/- 1.0 adjustable
Power Factor Range (full-rated power)	+/- 0.85
Internal Battery DC Voltage	50 V
Round Trip Efficiency ^{1,2}	90%
Warranty	10 years

¹Values provided for 25°C, 3.3 kW charge/discharge power.

²AC to battery to AC, at beginning of life.

COMPLIANCE INFORMATION

Certifications	IEC 62109-1, IEC 62109-2, IEC 62619, UN 38.3
Grid Connection	Worldwide Compatibility
Emissions	IEC 61000-6-1, IEC 61000-6-3
Environmental	RoHS Directive 2011/65/EU, WEEE Directive 2012/19/EU, Battery Directive 2006/66/EC, REACH Regulation
Seismic	AC156, IEEE 693-2005 (high)

MECHANICAL SPECIFICATIONS

Dimensions	1150 mm x 755 mm x 155 mm
Weight	125 kg
Mounting options	Floor or wall mount

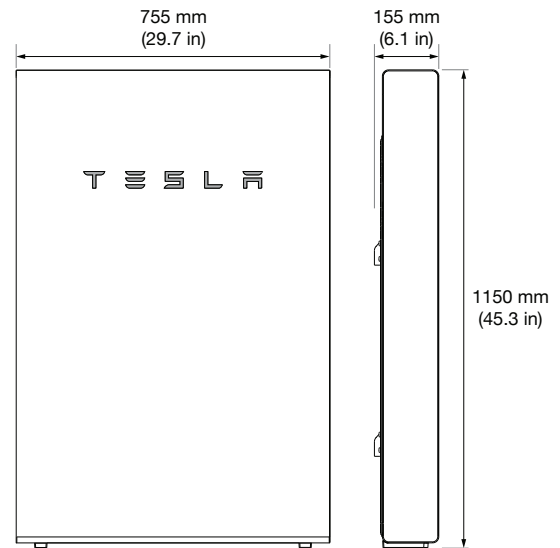

ENVIRONMENTAL SPECIFICATIONS

Operating Temperature	-20°C to 50°C
Optimum Temperature	0°C to 30°C
Operating Humidity (RH)	Up to 100%, condensing
Maximum Elevation	3000 m
Environment	Indoor and outdoor rated
Ingress Rating	IP67 (Battery & Power Electronics) IP56 (Wiring Compartment)
Noise Level @ 1m	< 40 dBA at 30°C

TYPICAL SYSTEM LAYOUT

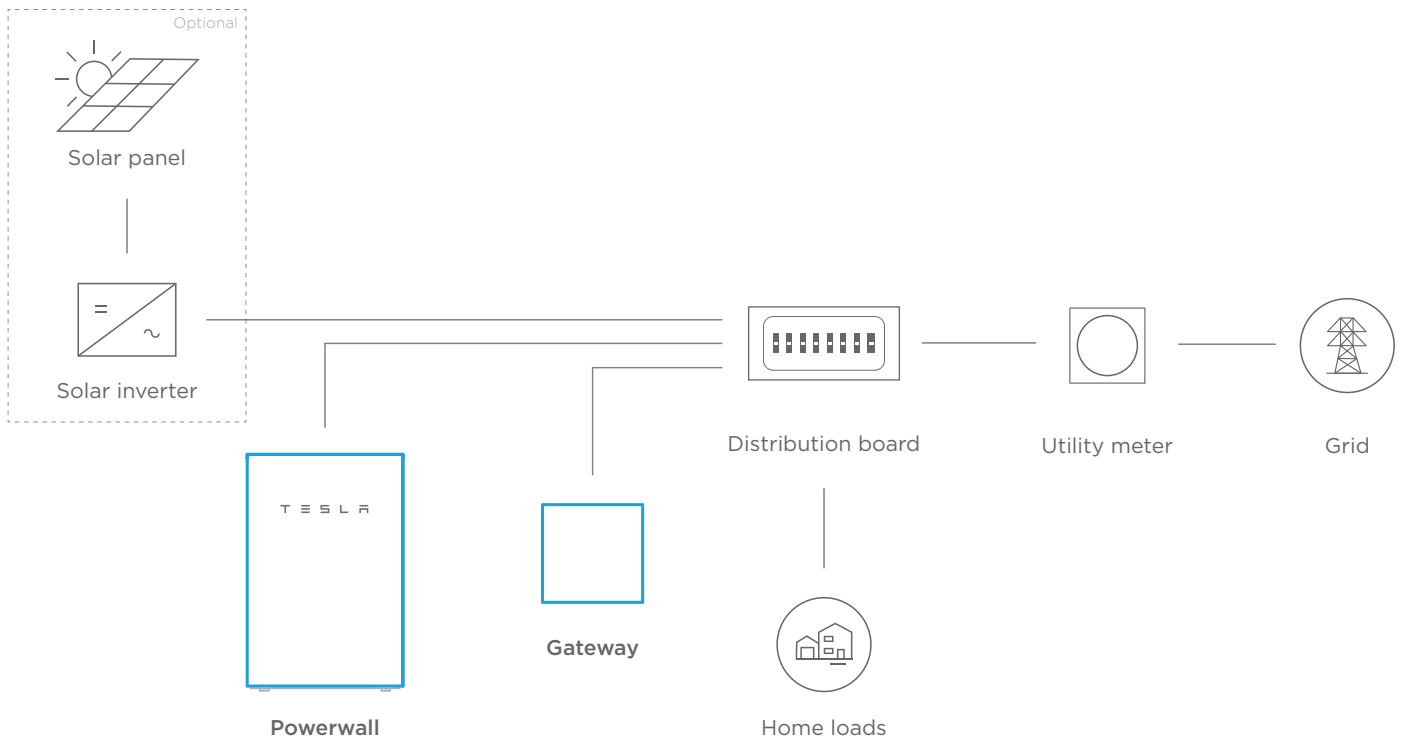

POWERWALL

Tesla Powerwall is a fully-integrated AC battery system for residential or light commercial use. Its rechargeable lithium-ion battery pack provides energy storage for solar self-consumption, time-based control, and backup.

Powerwall's electrical interface provides a simple connection to any home or building. Its revolutionary compact design achieves market-leading energy density and is easy to install, enabling owners to quickly realize the benefits of reliable, clean power.



PERFORMANCE SPECIFICATIONS

AC Voltage (Nominal)	120/240 V
Feed-In Type	Split Phase
Grid Frequency	60 Hz
Total Energy	14 kWh
Usable Energy	13.5 kWh
Real Power, max continuous	5 kW (charge and discharge)
Real Power, peak (10s, off-grid/backup)	7 kW (charge and discharge)
Apparent Power, max continuous	5.8 kVA (charge and discharge)
Apparent Power, peak (10s, off-grid/backup)	7.2 kVA (charge and discharge)
Maximum Supply Fault Current	10 kA
Maximum Output Fault Current	32 A
Overcurrent Protection Device	30 A
Imbalance for Split-Phase Loads	100%
Power Factor Output Range	+/- 1.0 adjustable
Power Factor Range (full-rated power)	+/- 0.85
Internal Battery DC Voltage	50 V
Round Trip Efficiency ^{1,3}	90%
Warranty	10 years

¹Values provided for 25°C (77°F), 3.3 kW charge/discharge power.

²In Backup mode, grid charge power is limited to 3.3 kW.

³AC to battery to AC, at beginning of life.

COMPLIANCE INFORMATION

Certifications	UL 1642, UL 1741, UL 1973, UL 9540, IEEE 1547, UN 38.3
Grid Connection	Worldwide Compatibility
Emissions	FCC Part 15 Class B, ICES 003
Environmental	RoHS Directive 2011/65/EU
Seismic	AC156, IEEE 693-2005 (high)

MECHANICAL SPECIFICATIONS

Dimensions ¹	1150 mm x 755 mm x 147 mm (45.3 in x 29.6 in x 5.75 in)
Weight ¹	114 kg (251.3 lbs)
Mounting options	Floor or wall mount

¹Dimensions and weight differ slightly if manufactured before March 2019. Contact Tesla for additional information.

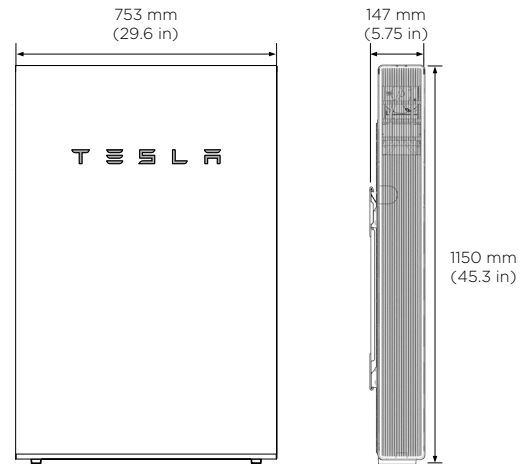

ENVIRONMENTAL SPECIFICATIONS

Operating Temperature	-20°C to 50°C (-4°F to 122°F)
Recommended Temperature	0°C to 30°C (32°F to 86°F)
Operating Humidity (RH)	Up to 100%, condensing
Storage Conditions	-20°C to 30°C (-4°F to 86°F) Up to 95% RH, non-condensing State of Energy (SoE): 25% initial
Maximum Elevation	3000 m (9843 ft)
Environment	Indoor and outdoor rated
Enclosure Type	NEMA 3R
Ingress Rating	IP67 (Battery & Power Electronics) IP56 (Wiring Compartment)
Wet Location Rating	Yes
Noise Level @ 1m	< 40 dBA at 30°C (86°F)

TYPICAL SYSTEM LAYOUTS

WHOLE HOME BACKUP

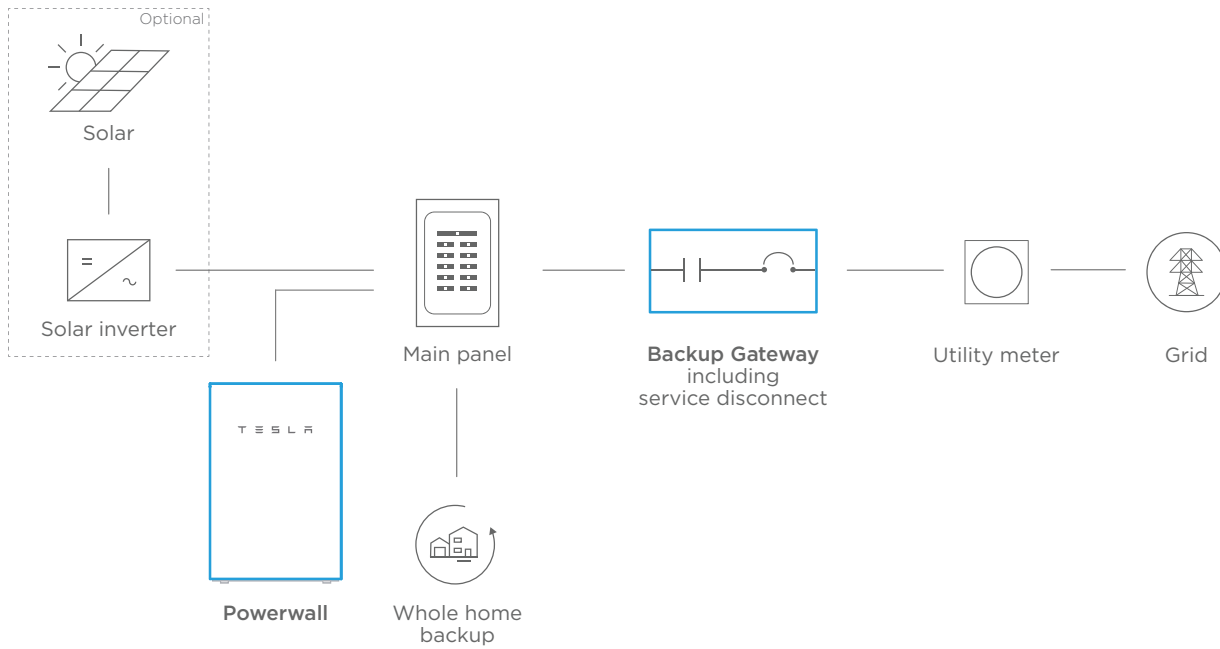

PARTIAL HOME BACKUP

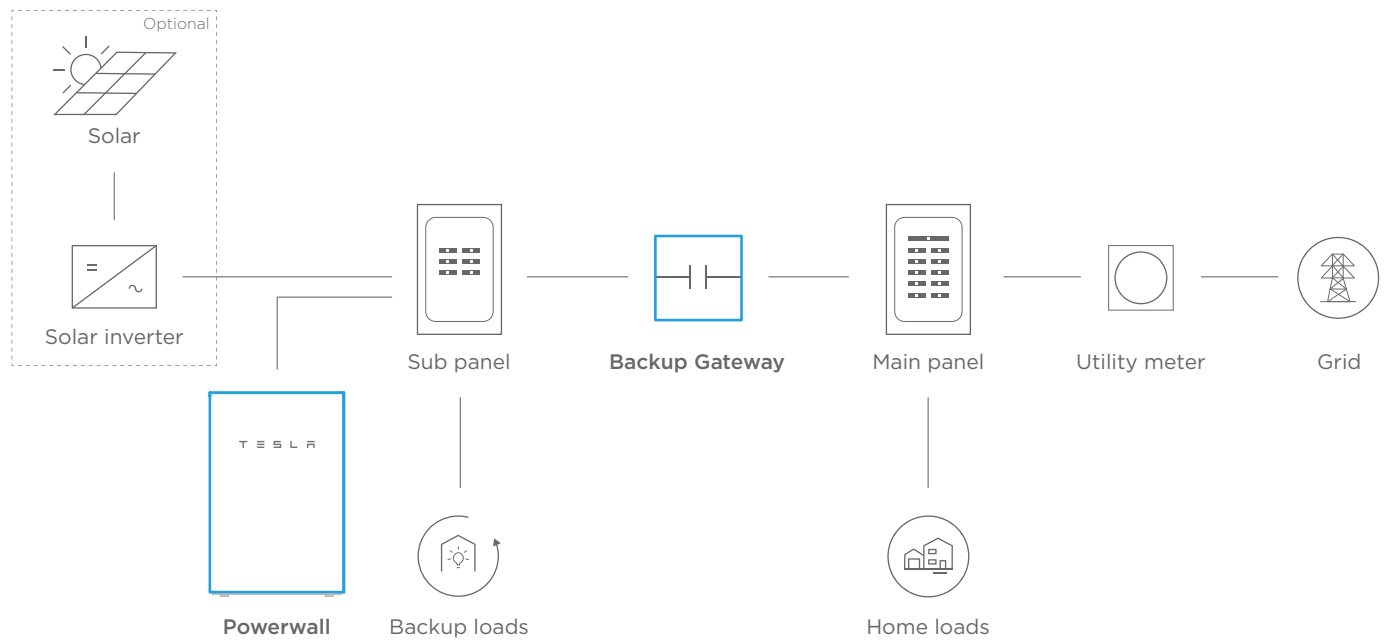

Powerwall 3

Power Everything

—
Powerwall 3 is a fully integrated solar and battery system, designed to accelerate the transition to sustainable energy. Customers can receive whole home backup, cost savings, and energy independence by producing and consuming their own energy while participating in grid services. Once installed, customers can manage their system using the Tesla App to customize system behavior to meet their energy goals.

Powerwall 3 achieves this by supporting up to 20 kW DC of solar and providing 11.5 kW AC of continuous power per unit. It has the ability to start heavy loads up to 150 A LRA, meaning a single unit can support the power needs of most homes. Powerwall 3 is designed for mass production, fast and efficient installations, easy system expansion, and simple connection to any electrical service.



Powerwall 3 Technical Specifications

System Technical Specifications

Model Number	1707000-xx-y
Nominal Grid Voltage (Input & Output)	120/240 VAC
Grid Type	Split phase
Frequency	60 Hz
Overcurrent Protection Device	Configurable up to 60 A
Solar to Battery to Grid Round Trip Efficiency	89% ^{1,2}
Solar to Grid Efficiency	97% ³
Supported Islanding Devices	Backup Gateway 2, Backup Switch
Connectivity	Wi-Fi (2.4 and 5 GHz), Dual-port switched Ethernet, Cellular (LTE/4G ⁴)
Hardware Interface	Dry contact relay, Rapid Shutdown (RSD) certified switch and 2-pin connector, RS-485 for meters
AC Metering	Revenue Grade (+/- 0.5%)
Protections	Integrated arc fault circuit interrupter (AFCI), Isolation Monitor Interrupter (IMI), PV Rapid Shutdown (RSD) using Tesla Mid-Circuit Interrupters
Customer Interface	Tesla Mobile App
Warranty	10 years

Solar Technical Specifications

Maximum Solar STC Input	20 kW
Withstand Voltage	600 V DC
PV DC Input Voltage Range	60 – 550 V DC
PV DC MPPT Voltage Range	150 – 480 V DC
MPPTs	6
Maximum Current per MPPT (I_{mp})	13 A ⁵
Maximum Short Circuit Current per MPPT (I_{sc})	15 A ⁵

Battery Technical Specifications

Nominal Battery Energy	13.5 kWh AC ²
Maximum Continuous Discharge Power	11.5 kW AC
Maximum Continuous Charge Power	5 kW AC
Output Power Factor Rating	0 - 1 (Grid Code configurable)
Maximum Continuous Current	48 A
Maximum Output Fault Current	10 kA
Load Start Capability (1 s)	150 A LRA
Power Scalability	Up to 4 Powerwall 3 units supported

¹ Typical solar shifting use case.

² Values provided for 25°C (77°F), at beginning of life. 3.3 kW charge/discharge power.

³ Tested using CEC weighted efficiency methodology.

⁴ Cellular connectivity subject to network service coverage and signal strength.

⁵ Where the DC input current exceeds the MPPT rating, a jumper can be used to combine two MPPTs into a single input to intake DC current up to 26 A I_{mp} / 30 A I_{sc} .

Powerwall 3 Technical Specifications

Environmental Specifications

Operating Temperature	-20°C to 50°C (-4°F to 122°F) ⁶
Operating Humidity (RH)	Up to 100%, condensing
Storage Temperature	-20°C to 30°C (-4°F to 86°F), up to 95% RH, non-condensing, State of Energy (SOE): 25% initial
Maximum Elevation	3000 m (9843 ft)
Environment	Indoor and outdoor rated
Enclosure Rating	NEMA 3R
Ingress Rating	IPX7 (Battery & Power Electronics) IPX5 (Wiring Compartment)
Pollution Rating	PD3
Operating Noise @ 1 m	< 50 db(A) typical < 62 db(A) maximum

⁶ Performance may be de-rated at operating temperatures above 40°C (104°F).

Compliance Information

Certifications	UL 1642, UL 1699B, UL 1741, UL 1741 SA, UL 1741 SB, UL 3741, UL 1973, UL 1998, UL 9540, IEEE 1547-2018, IEEE 1547.1, UN 38.3
Grid Connection	United States
Emissions	FCC Part 15 Class B
Environmental	RoHS Directive 2011/65/EU
Seismic	AC156, IEEE 693-2005 (high)
Fire Testing	Meets the unit level performance criteria of UL 9540A

Mechanical Specifications

Dimensions	1099 x 609 x 193 mm (43.25 x 24 x 7.6 in)
Weight	130 kg (287 lb)
Mounting Options	Floor or wall mount

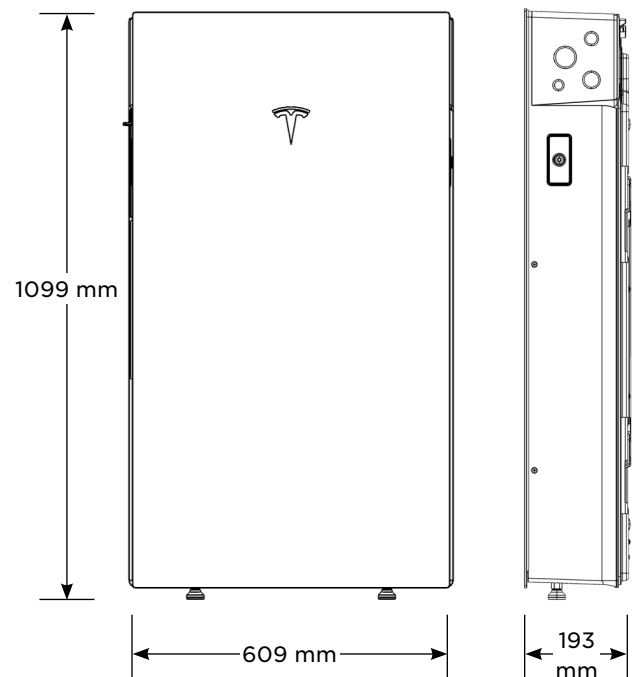

Solar Shutdown Device Technical Specifications

The Solar Shutdown Device is a Mid-Circuit Interrupter (MCI) and is part of the PV system rapid shutdown (RSD) function in accordance with Article 690 of the applicable NEC. When paired with Powerwall 3, solar array shutdown is initiated by any loss of AC power.

Electrical Specifications	Model	MCI-1	MCI-2
	Nominal Input DC Current Rating (I_{MP})	12 A	13 A
	Maximum Input Short Circuit Current (I_{SC})	19 A	17 A
	Maximum System Voltage (PVHCS)	600 V DC	1000 V DC ⁷
⁷ Maximum System Voltage is limited by Powerwall to 600 V DC.			
RSD Module Performance	Maximum Number of Devices per String	5	5
	Control	Power Line Excitation	Power Line Excitation
	Passive State	Normally Open	Normally Open
	Maximum Power Consumption	7 W	7 W
	Warranty	25 years	25 years
Environmental Specifications	Operating Temperature	-40°C to 50°C (-40°F to 122°F)	-45°C to 70°C (-49°F to 158°F)
	Storage Temperature	-30°C to 70°C (-22°F to 158°F)	-30°C to 70°C (-22°F to 158°F)
	Enclosure Rating	NEMA 4X / IP65	NEMA 4X / IP65
Mechanical Specifications	Electrical Connections	MC4 Connector	MC4 Connector
	Housing	Plastic	Plastic
	Dimensions	125 x 150 x 22 mm (5 x 6 x 1 in)	173 x 45 x 22 mm (6.8 x 1.8 x 1 in)
	Weight	350 g (0.77 lb)	120 g (0.26 lb)
	Mounting Options	ZEP Home Run Clip M4 Screw (#10) M8 Bolt (5/16") Nail / Wood screw	Wire Clip
Compliance Information	Certifications	UL 1741 PVRSE, UL 3741, PVRSA (Photovoltaic Rapid Shutdown Array)	
	RSD Initiation Method	External System Shutdown Switch or Powerwall 3 Enable Switch	

UL 3741 PV Hazard Control (and PVRSA) Compatibility

The following categories of solar module meet the UL 3741 PVHCS listing when installed with Powerwall 3 and Solar Shutdown Devices.

Tesla Solar Roof	PV Hazard Control System: BIPV compliance document
Tesla or Hanwha (Q.Peak Duo BLK or BLK-G6+) Modules certified for use with ZEP racking	PV Hazard Control System: ZS PVHCS compliance document
Other module and racking combinations	PV Hazard Control System: Generic PV Array compliance document

Backup Gateway 2

Backup Gateway 2 controls connection to the grid when paired with Powerwall 3, automatically detecting outages and providing seamless transition to backup power. Backup Gateway 2 also provides energy metering for solar self-consumption, time-based control, and backup operation.

In this system configuration, Powerwall 3 acts as the Site Controller, with the Backup Gateway 2 Site Controller disabled.

Performance Specifications

Model Number	1232100-xx-y
AC Voltage (Nominal)	120/240 V
Feed-in Type	Split phase
Grid Frequency	60 Hz
Current Rating	200 A
Maximum Supply Short Circuit Current	10 kA ⁸
Overcurrent Protection Device	100 - 200 A, Service entrance rated ⁸
Overvoltage Category	Category IV
Internal Primary AC Meter	Revenue accurate (+/- 0.2%)
Internal Auxiliary AC Meter	Revenue accurate (+/- 2%)
Primary Connectivity	Ethernet, Wi-Fi
Secondary Connectivity	Cellular (3G, LTE/4G) ⁹

User Interface	Tesla App
Operating Modes	Support for solar self-consumption, time-based control, and backup
Backup Transition	Automatic disconnect for seamless backup
Modularity	Supports up to 10 AC-coupled Powerwalls
Optional Internal Panelboard	200 A 6-space / 12 circuit breakers Siemens QP or Square D HOM breakers rated 10 - 80A or Eaton BR breakers rated 10 - 125A
Warranty	10 years

⁸ When protected by Class J fuses, Backup Gateway 2 is suitable for use in circuits capable of delivering not more than 22kA symmetrical amperes.

⁹ The customer is expected to provide internet connectivity for Backup Gateway 2; cellular should not be used as the primary mode of connectivity. Cellular connectivity subject to network operator service coverage and signal strength.

Environmental Specifications

Operating Temperature	-20°C to 50°C (-4°F to 122°F)
Operating Humidity (RH)	Up to 100%, condensing
Maximum Elevation	3000 m (9843 ft)
Environment	Indoor and outdoor rated
Enclosure Type	NEMA 3R

Compliance Information

Certifications	UL 67, UL 869A, UL 916, UL 1741 PCS, CSA 22.2 0.19, CSA 22.2 205
Emmissions	FCC Part 15, ICES 003

Mechanical Specifications

Dimensions	660 x 411 x 149 mm (26 x 16 x 6 in)
Weight	20.4 kg (45 lb)
Mounting options	Wall mount, Semi-flush mount

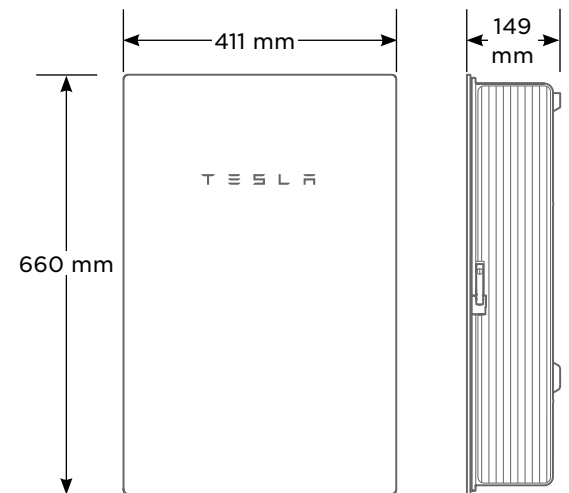

Backup Switch

The Tesla Backup Switch controls connection to the grid in a Powerwall system, and can be easily installed behind the utility meter or in a standalone meter panel downstream of the utility meter.

The Backup Switch automatically detects grid outages, providing a seamless transition to backup power. It communicates directly with Powerwall, allowing home energy usage monitoring from any mobile device with the Tesla app.

Performance Specifications

Model Number	1624171-xx-y
Continuous Load Rating	200 A, 120/240 V split phase
Maximum Supply Short Circuit Current	22 kA with breaker ¹⁰
Communication	CAN
AC Meter	Revenue accurate (+/- 0.5%)
Expected Service Life	21 years
Warranty	10 years

¹⁰ Breaker maximum supply short circuit current rating must be equal to or greater than the available fault current.

Environmental Specifications

Operating Temperature	-40°C to 50°C (-40°F to 122°F)
Storage Temperature	-40°C to 85°C (-40°F to 185°F)
Enclosure Rating	NEMA 3R
Pollution Rating	PD3

Compliance Information

Safety Standards	USA: UL 414, UL 2735, UL 916, CA Prop 65
Emmissions	FCC, ICES

Mechanical Specifications

Dimensions	176 x 205 x 74 mm (6.9 x 8.1 x 2.9 in)
Weight	2.8 lb
Meter and Socket Compatibility	ANSI Type 2S, ringless or ring type
External Service Interface	Contactor manual override ¹¹ Reset button
Conduit Compatibility	1/2-inch NPT

¹¹ Manually overrides the contactor position during a service event.

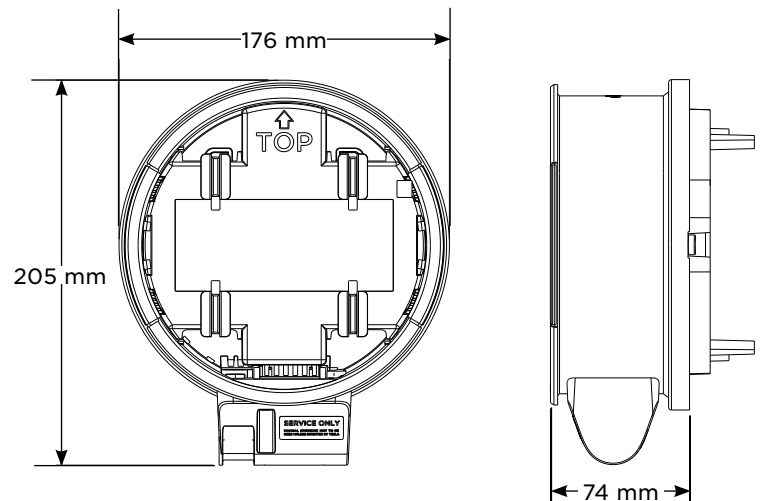

Powerwall 3 Example System Configurations

Powerwall 3 with Backup Switch

Whole Home Backup

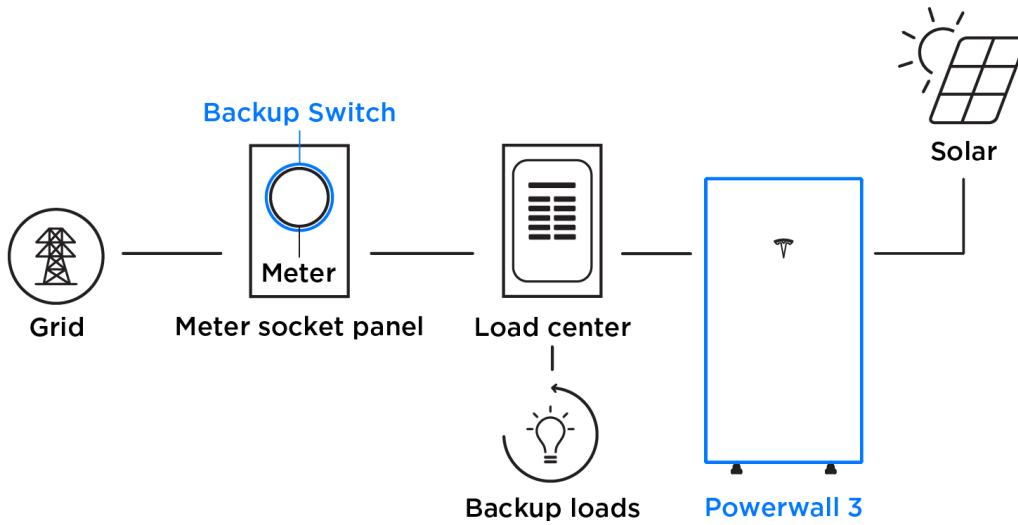

Powerwall 3 with Backup Gateway 2

Partial Home Backup

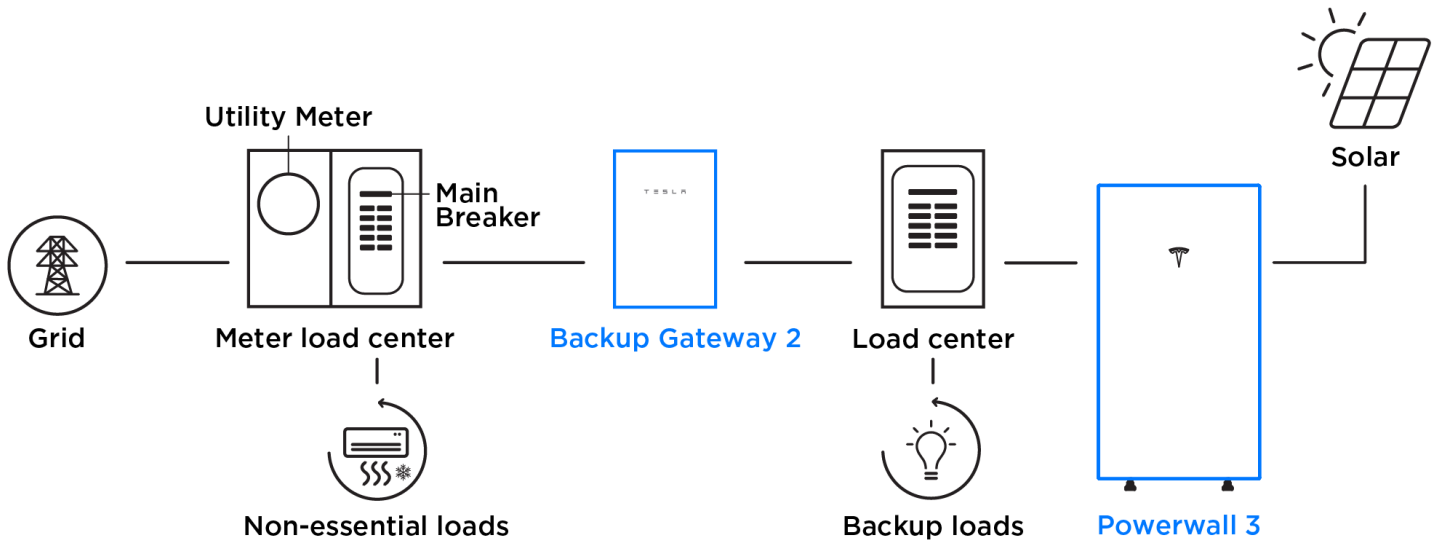

POWERWALL

The Tesla Powerwall is a wall-mounted battery system for residential or light commercial use. Its rechargeable lithium-ion battery pack provides energy storage for solar self-consumption, load shifting, backup power, or any high-throughput application. Powerwall's electrical interface is provided by an internal isolated bi-directional DC/DC converter controlling the charge and discharge of the battery for integration with utility-interactive inverters.

Powerwall achieves unprecedented levels of safety in home energy storage. It is a factory assembled, fully-certified unit that contains no user serviceable parts. The microprocessor controlled DC/DC converter is electrically isolated from the internal battery and eliminates user access to live terminals during installation or service.



ELECTRICAL SPECIFICATIONS

Power, continuous and peak	3.3 kW
Energy*	6.4 kWh
Internal Battery Voltage	< 50 VDC
System Operating Voltage	350 V–450 V
Voltage in OFF State	0 VDC
Current	9.5 ADC
Round Trip Efficiency*	92.5% (for a 400 V–450 V DC bus)
Depth of Discharge	100%
Equivalent Cycles	Unlimited cycles (provided Powerwall is only used for solar self-consumption and backup)

* Values provided for 25°C (77°F), 2 kW charge/discharge power

ENVIRONMENTAL SPECIFICATIONS

Operating temperature	–20° C to 50° C (–4° F to 122° F)
Relative humidity	100% condensing
Maximum altitude	3000 m (9843 ft)
Impact Rating	IK09
Ingress Rating	IP35 & NEMA 3R (Powerwall) IP67 (Battery Pod)

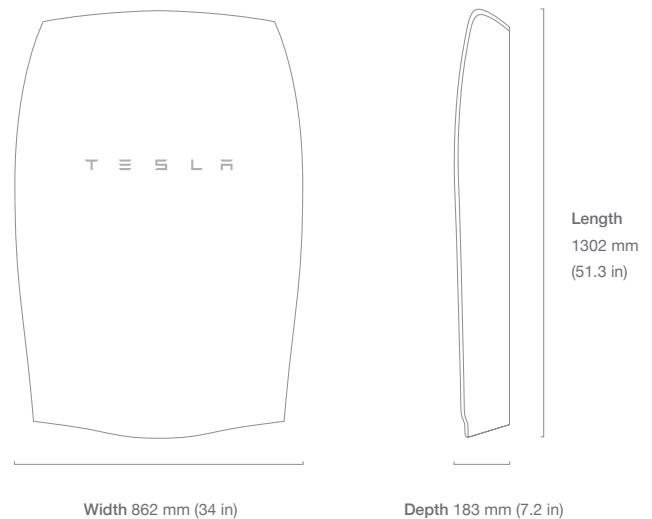

MECHANICAL SPECIFICATIONS

Dimensions	1302 mm (51.3 in) x 862 mm (34 in) x 183 mm (7.2 in)
Weight	97 kg (214 lbs)

CERTIFICATIONS

Powerwall	UL 9540, AC156 seismic certification, IEEE 693-2005 seismic certification, FCC Part 15 Class B, IEC/EN 61000 Class B
Battery/Pod	UL 1642, UL 1741, UL 1973, UN 38.3, REACH, Battery Directive 2006/66/EC, RoHS Directive 2011/65/EU, WEEE Directive 2012/19/EU, IEC 62109-1, IEC 62619, CSA C22.2.107.1

POWERWALL

Tesla Powerwall is a fully-integrated AC battery system for residential or light commercial use. Its rechargeable lithium-ion battery pack provides energy storage for solar self-consumption, time-based control, and backup.

Powerwall's electrical interface provides a simple connection to any home or building. Its revolutionary compact design achieves market-leading energy density and is easy to install, enabling owners to quickly realize the benefits of reliable, clean power.



PERFORMANCE SPECIFICATIONS

AC Voltage (Nominal)	230 V
Feed-In Type	Single Phase
Grid Frequency	50 Hz
Total Energy¹	14 kWh
Usable Energy¹	13.5 kWh
Real Power, max continuous²	5 kW (charge and discharge)
Apparent Power, max continuous	5 kVA (charge and discharge)
Maximum Supply Fault Current	10 kA
Maximum Output Fault Current	32 A
Power Factor Output Range	+/- 1.0 adjustable
Internal Battery DC Voltage	50 V
Round Trip Efficiency^{1,3}	90%
Warranty	10 years

¹Values provided for 25°C, 3.3 kW charge/discharge power.

²In Backup mode, grid charge power is limited to 3.3 kW.

³AC to battery to AC, at beginning of life.

COMPLIANCE INFORMATION

Certifications	IEC 62109-1, IEC 62109-2, IEC 62619, UN 38.3
Grid Connection	Worldwide Compatibility
Emissions	IEC 61000-6-1, IEC 61000-6-3
Environmental	RoHS Directive 2011/65/EU, WEEE Directive 2012/19/EU, Battery Directive 2006/66/EC, REACH Regulation
Seismic	AC156, IEEE 693-2005 (high)

MECHANICAL SPECIFICATIONS

Dimensions¹	1150 mm x 753 mm x 147 mm
Weight	114 kg
Mounting options	Floor or wall mount

¹Dimensions and weight differ slightly if manufactured before March 2019. Contact Tesla for additional information.

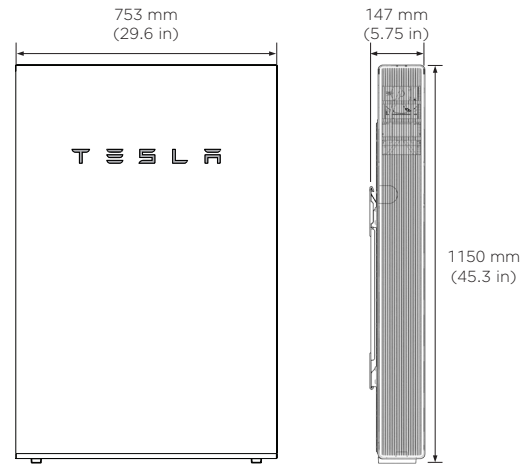

ENVIRONMENTAL SPECIFICATIONS

Operating Temperature	-20°C to 50°C
Recommended Temperature	0°C to 30°C
Operating Humidity (RH)	Up to 100%, condensing
Storage Conditions	-20°C to 30°C Up to 95% RH, non-condensing State of Energy (SoE): 25% initial
Maximum Elevation	3000 m
Environment	Indoor and outdoor rated
Ingress Rating	IP67 (Battery & Power Electronics) IP56 (Wiring Compartment)
Wet Location Rating	Yes
Noise Level @ 1m	< 40 dBA at 30°C

TYPICAL SYSTEM LAYOUTS

WHOLE HOME BACKUP

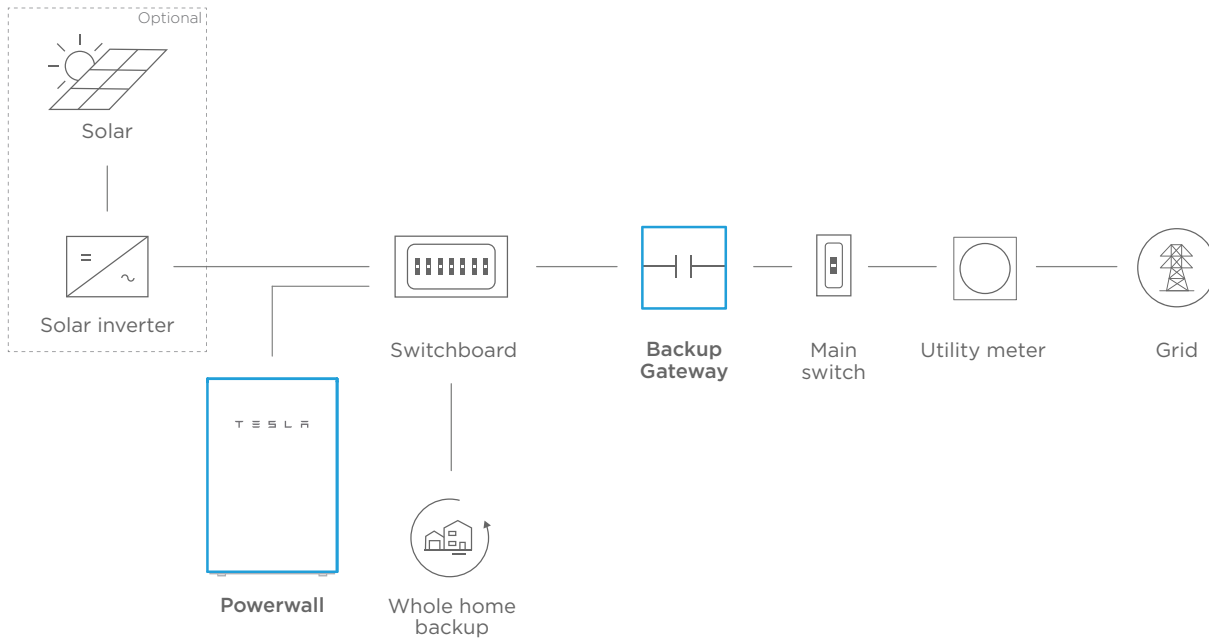

PARTIAL HOME BACKUP

